

**CLUC-72R**  
**Compact Worktop Refrigerator**  
**Self-Contained Glass Doors**



**STANDARD PRODUCT FEATURES**

- High Quality Stainless Steel Construction
- Anodized Aluminum Interior
- 4" Backsplash
- Stay Open Door Feature at 105°
- LED Display Control for Accuracy and Easy Monitoring
- Capillary Tube Metering Device
- Maintains Cabinet Temperature of 32°F to 41°F
- Two (2) Adjustable, Heavy Duty Epoxy Coated Shelves Per Section
- Field Reversible Door(s)
- Set of Four (6) 4" H Casters, Front Three w/ Locks, Pre-installed on Device
- Gasket-Protecting Retainer
- Self-Contained Rear Mounted Refrigeration System
- High-Density, Non-CFC Foamed In Place Polyurethane Insulation
- Easy to Grip Metal Door Handle(s)



Models listed to the applicable UL, CSA and NSF standards by an approved NRTL. Consult the factory or unit data plate for additional information.

**ACCESSORIES & OPTIONS (Available at Extra Cost)**

- + Additional Epoxy Coated Shelves on Pilasters
- + Set of Four (4) 6" High Legs
- + Set of Six (6) 6" High Casters
- + Set of Four (4) 2-3/4" High Casters

**AVAILABLE CONFIGURATIONS**

MODELS	HINGING
CLUC-72R-GD-WTLRR	Glass Doors, Left/Right/Right
CLUC-72R-GD-WTRRR	Glass Doors, Right/Right/Right
CLUC-72R-GD-WTLLL	Glass Doors, Left/Left/Left

Model	Doors	Shelves	Dimensions L x D x H (in.)	Voltage	Amps	NEMA	Cu. Ft.
CLUC-72R-GD-WT	3	6	72.19 x 33 x 34*	115/60/1	3.6	5 - 15P	18.80

\*Note: 30 in. height without casters

Approved by \_\_\_\_\_ Date \_\_\_\_\_ Approved by \_\_\_\_\_ Date \_\_\_\_\_

**MODEL - CLUC-72R-GD-WT**

Glass Door Models

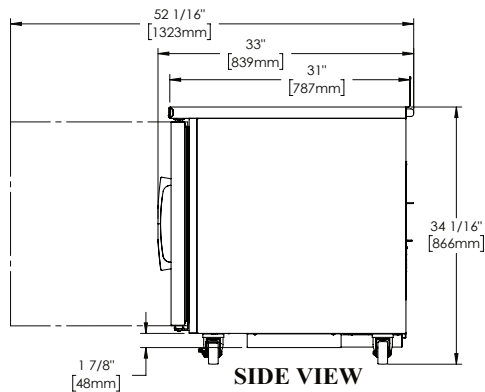
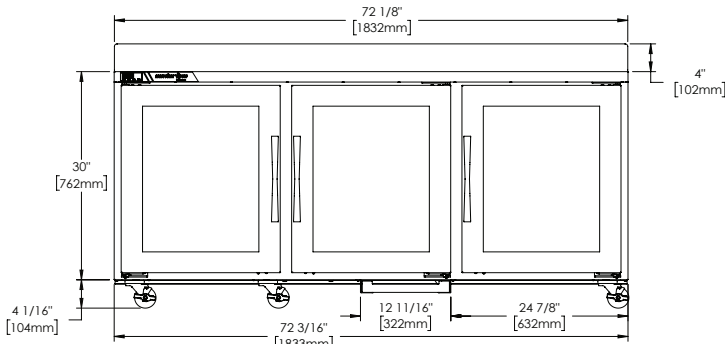
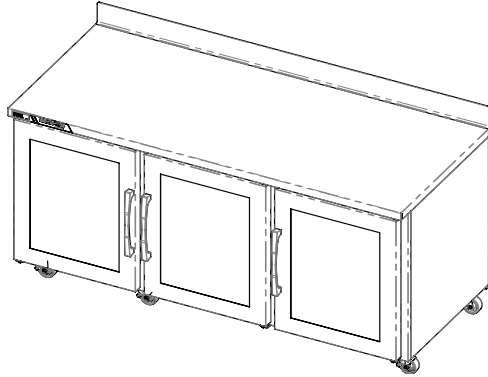

**SPECIFICATIONS**

**CONSTRUCTION, HARDWARE, INSULATION**

Cabinet exterior front, sides, and door frames are constructed of stainless steel and glass doors. Cabinet interior is constructed of anodized aluminum. A set of four (4) 4" high casters are included. Doors are equipped with a gasket protecting retainer. Both the cabinet and door(s) are insulated with an average of 2-3/8" thick high density, non-CFC, foamed in place polyurethane insulation.

**REFRIGERATION SYSTEM**

A rear mounted, self-contained, balanced refrigeration system using environmentally friendly, non flammable R-450A refrigerant is provided. It features an easy to clean rear facing condenser, capillary tube metering device, and air-cooled hermetic compressor. A 9' cord and plug is provided. Standard operating temperature is 32°F to 41°F. Energy efficient refrigeration system maintains safe product temperatures. Condenser is located in the back of the unit for easy maintenance and zero clearance.

**CONTROLLER**

The easy to use electronic digital control is supplied standard. It includes a 3-Digit LED display, and a Fahrenheit or Celsius temperature scale display capability.

**INTERIOR**

Standard interior arrangements include two (2) epoxy coated wire shelves per section, mounted on pilasters. Recommended load limit per shelf should not exceed 150 lbs.

**WARRANTY**

Both a 6 Year Parts & Labor Warranty and additional 1 Year on Compressor Parts Warranty are supplied standard.

MODELS	CLUC-72R-GD-WT
<b>ELECTRICAL DATA</b>	
Voltage	115/60/1
Full Load Amperes	3.6
<b>REFRIGERATION DATA</b>	
Refrigerant	R-450A
Refrigerant Charge oz.	11.0 (312 gr)
BTU/HR   H.P. <sup>1</sup>	1900   1/4
<b>SHIPPING DATA</b>	
Depth Crated in.	35 (88.9 cm)
Height Crated in.	37 (94 cm)
Length Crated in.	77 (195.6 cm)
Volume Crated cu. ft.	57.7 (1634 l)
Net Weight lbs.	310 (140.4 kg)
Gross Weight lbs.	344 (156 kg)

NOTES:  
1. BTU/HR based on a 90°F ambient and 20°F evaporator

Equipped with one NEMA 5-15P Plug

