

**CLPT-6016**  
**Compact Sandwich Prep Table**  
**Self-Contained Drawers**



**STANDARD PRODUCT FEATURES**

- High Quality Stainless Steel Construction
- Anodized Aluminum Interior
- LED Display Control for Accuracy and Easy Monitoring
- Capillary Tube Metering Device
- 12" Deep, 3/4" Thick, Full Length Removable Cutting Board
- NSF Approved White Polyethylene Board
- Maintains Cabinet Temperature of 32°F to 41°F
- Insulated Hood
- NSF Rated for Use with 6" Deep Pans
- Top Cut-Out Accommodates 1/6 Size Pans (4" deep plastic pans provided)
- Four (4) Fully Removable Drawers
- Each Drawer Accommodates Full Size 6" Deep Pans
- Easy to Grip Drawer Handle(s)
- Set of Four (4) 4" H Casters, Front Two w/ Locks, Pre-installed on Device
- Gasket-Protecting Retainer
- Self-Contained Rear-Mounted Refrigeration System
- High-Density, Non-CFC Foamed in Place Polyurethane Insulation



Models listed to the applicable UL, CSA and NSF standards by an approved NRTL. Consult the factory or unit data plate for additional information.

**ACCESSORIES & OPTIONS (Available at Extra Cost)**

- + Set of Four (4) 6" High Legs
- + Set of Four (4) 6" High Casters
- + Set of Four (4) 2-3/4" High Casters

**AVAILABLE CONFIGURATIONS**

**MODELS**

CLPT-6016-DW                      Four (4) Drawers

Model	Drawers	Pans (1/6)	Dimensions L x D x H (in.)	Voltage	Amps	NEMA	Cu. Ft.
CLPT-6016	4	16	60.56 x 32.75 x 40*	115/60/1	5.0	5 - 15P	N/A

\*Note: 40 in. height without casters

Approved by \_\_\_\_\_ Date \_\_\_\_\_ Approved by \_\_\_\_\_ Date \_\_\_\_\_

**MODEL - CLPT-6016**

Drawer Models

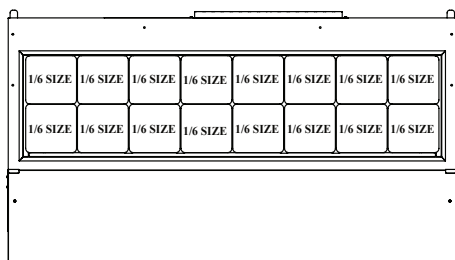
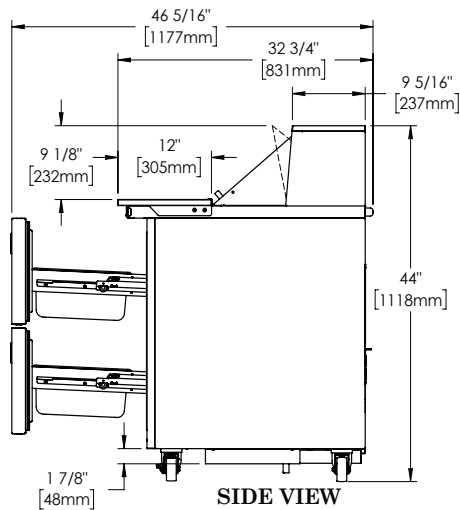
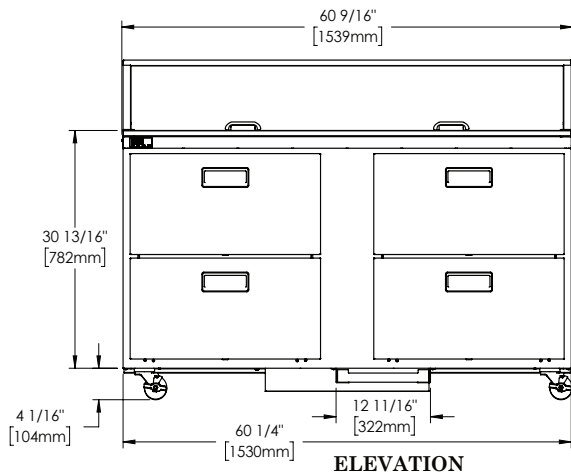

**SPECIFICATIONS**

**CONSTRUCTION, HARDWARE, INSULATION**

Cabinet exterior front, sides, and drawers are constructed of stainless steel. Cabinet interior is constructed of anodized aluminum. 1/6 size plastic pans and a set of four (4) 4" high casters are included. Drawers are equipped with a gasket protecting retainer. Both the cabinet and drawers are insulated with an average of 2-3/8" thick high density, non-CFC, foamed in place polyurethane insulation.

**REFRIGERATION SYSTEM**

A rear mounted, self-contained, balanced refrigeration system using environmentally friendly, non-flammable R-450A refrigerant is provided. It features an easy to clean rear facing condenser, capillary tube metering device, and an air-cooled hermetic compressor. A 9' cord and plug is provided. Standard operating temperature is 32°F to 41°F. Energy efficient refrigeration system maintains safe product temperatures. Condenser is located in back of unit for easy maintenance and zero clearance.

**CONTROLLER**

The easy to use electronic digital control is supplied standard. It includes a 3-Digit LED display, and a Fahrenheit or Celsius temperature scale display capability.

**DRAWERS**

Drawer exterior, liner, and frame are constructed of stainless steel. Each drawer has foamed-in place recessed handle for easy grip. Heavy-duty drawers are removable without tools for easy cleaning. Each drawer accommodates one (1) 6" deep full size food pan (sold separately).

**WARRANTY**

Both a 6 Year Parts & Labor Warranty and additional 1 Year on Compressor Parts Warranty are supplied standard.

MODELS	CLPT-6016
<b>ELECTRICAL DATA</b>	
Voltage	115/60/1
Full Load Amperes	5.0
<b>REFRIGERATION DATA</b>	
Refrigerant	R-450A
Refrigerant Charge oz.	11.0 (312 gr)
BTU/HR <sup>1</sup>   H.P.	2134   1/4
<b>SHIPPING DATA</b>	
Depth Crated in.	35 (88.9 cm)
Height Crated in.	49 (124.5 cm)
Length Crated in.	65 (165.1 cm)
Volume Crated cu. ft.	64.5 (1827 cm <sup>3</sup> )
Net Weight lbs.	352 (159.6 kg)
Gross Weight lbs.	391 (177.4 kg)

**NOTES:**

1. BTU/HR based on a 90°F ambient and 20°F evaporator

Equipped with one NEMA 5-15P Plug



**CAD and/or Revit Files Available**

As continued product improvement is a policy of Traulsen, specifications are subject to change without notice.