

CLPT-2712-DW
Compact Mega Top Prep Table
Self-Contained Drawers



STANDARD PRODUCT FEATURES

- High Quality Stainless Steel Construction
- Anodized Aluminum Interior
- Mega Top Pan Capacity for Extra Food Storage
- LED Display Control for Accuracy and Easy Monitoring
- Capillary Tube Metering Device
- 8" Deep, 3/4" Thick, Full Length Removable Cutting Board
- NSF Approved White Polyethylene Board
- Maintains Cabinet Temperature of 32°F to 41°F
- Insulated Hood
- NSF Rated for Use with 6" Deep Pans
- Top Cut-Out Accommodates 1/6 Size Pans (4" deep plastic pans provided)
- Two (2) Fully Removable Drawers
- Each Drawer Accommodates Full Size 6" Deep Pans
- Easy to Grip Drawer Handle(s)
- Set of Four (4) 4" H Casters, Front Two w/ Locks, Pre-installed on Device
- Gasket-Protecting Retainer
- Self-Contained Rear-Mounted Refrigeration System
- High-Density, Non-CFC Foamed in Place Polyurethane Insulation



Models listed to the applicable UL, CSA and NSF standards by an approved NRTL. Consult the factory or unit data plate for additional information.

ACCESSORIES & OPTIONS (Available at Extra Cost)

- + Set of Four (4) 6" High Legs
- + Set of Four (4) 6" High Casters
- + Set of Four (4) 2-3/4" High Casters

AVAILABLE CONFIGURATIONS

MODELS

CLPT-2712-DW Two (2) Drawers

Model	Drawers	Pans (1/6)	Dimensions L x D x H (in.)	Voltage	Amps	NEMA	Cu. Ft.
CLPT-2712-DW	2	12	27.88 x 35.75 x 40*	115/60/1	4.0	5 - 15P	N/A

*Note: 40 in. height without casters

Approved by _____ Date _____ Approved by _____ Date _____

MODEL - CLPT-2712-DW

Drawer Models - Mega Top

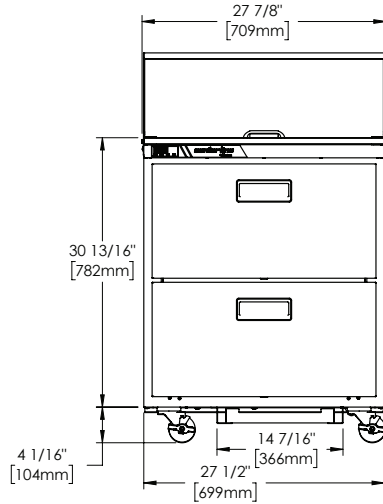

ELEVATION

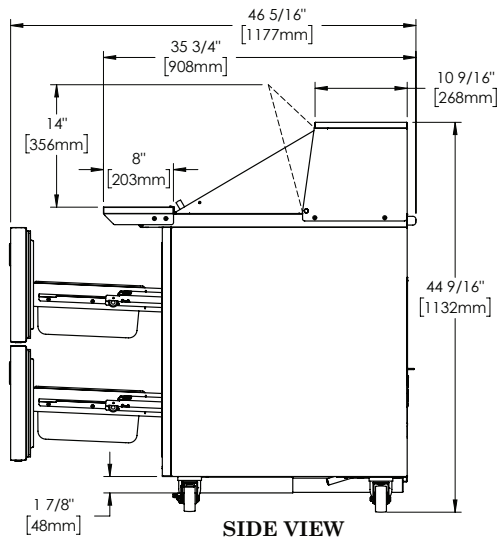

SIDE VIEW

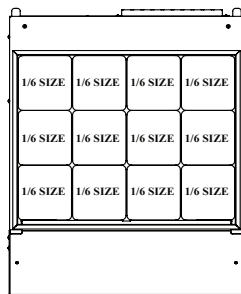

PAN LAYOUT

SPECIFICATIONS

CONSTRUCTION, HARDWARE, INSULATION

Cabinet exterior front, sides, and drawers are constructed of stainless steel. Cabinet interior is constructed of anodized aluminum. 1/6 size plastic pans and a set of four (4) 4" high casters are included. Drawers are equipped with a gasket protecting retainer. Both the cabinet and drawers are insulated with an average of 2-3/8" thick high density, non-CFC, foamed in place polyurethane insulation.

REFRIGERATION SYSTEM

A rear mounted, self-contained, balanced refrigeration system using environmentally friendly, non-flammable R-450A refrigerant is provided. It features an easy to clean rear facing condenser, capillary tube metering device, and an air-cooled hermetic compressor. A 9' cord and plug is provided. Standard operating temperature is 32°F to 41°F. Energy efficient refrigeration system maintains safe product temperatures. Condenser is located in back of unit for easy maintenance and zero clearance.

CONTROLLER

The easy to use electronic digital control is supplied standard. It includes a 3-Digit LED display, and a Fahrenheit or Celsius temperature scale display capability.

DRAWERS

Drawer exterior, liner, and frame are constructed of stainless steel. Each drawer has foamed-in place recessed handle for easy grip. Heavy-duty drawers are removable without tools for easy cleaning. Each drawer accommodates one (1) 6" deep full size food pan (sold separately).

WARRANTY

Both a 6 Year Parts & Labor Warranty and additional 1 Year on Compressor Parts Warranty are supplied standard.

MODELS	CLPT-2712-DW
ELECTRICAL DATA	
Voltage	115/60/1
Full Load Amperes	4.0
REFRIGERATION DATA	
Refrigerant	R-450A
Refrigerant Charge oz.	8.0 (227 gr)
BTU/HR ¹ H.P.	2134 1/4
SHIPPING DATA	
Depth Crated in.	35 (88.9 cm)
Height Crated in.	49 (124.5 cm)
Length Crated in.	32 (81.3 cm)
Volume Crated cu. ft.	31.8 (899 l)
Net Weight lbs.	229 (103.7 kg)
Gross Weight lbs.	254 (115.2 kg)

NOTES:

1. BTU/HR based on a 90°F ambient and 20°F evaporator

Equipped with one NEMA 5-15P Plug

