

**CLBM-23R**  
**Reach-In Refrigerator**  
**Self-Contained Glass Door**



**STANDARD PRODUCT FEATURES**

- Stainless Steel Sides, Door Frame(s) & Louver
- Anodized Aluminum Interior
- Metal Door Handle(s)
- Positive Seal Self-Closing Door(s) with Stay Open Feature at 110°
- LED Display Control for Accuracy and Easy Monitoring
- Capillary Tube Metering Device
- Three (3) Adjustable, Heavy Duty Epoxy Coated Shelves Per Section
- Field Reversible Door(s)
- Set of Four (4) 4" High Casters with Locks Standard on Front Casters
- Bottom-Mounted Refrigeration System
- High-Density, Non-CFC Foamed in Place Polyurethane Insulation
- Easily Accessible Condenser Coil for Cleaning
- Ergonomically Friendly Lower Shelf
- Storage on Top of Cabinet

**ACCESSORIES & OPTIONS (Available at Extra Cost)**

- + Additional Epoxy Coated Shelves on Pilasters
- + Additional Epoxy Coated Shelves on Pins
- + Set of Four (4) 6" High Legs
- + Set of Four (4) 6" High Casters
- + #1 or Universal Type Trayslides

**AVAILABLE CONFIGURATIONS**

**MODELS**

- CLBM-23R-FG-R
- CLBM-23R-FG-L
- CLBM-23R-HG-R
- CLBM-23R-HG-L

**HINGING**

- Full Glass Door, Right
- Full Glass Door, Left
- Half Glass Doors, Right
- Half Glass Doors, Left



Models listed to the applicable UL, CSA and NSF standards by an approved NRTL. Consult the factory or unit data plate for additional information.

Model	Doors	Shelves	Dimensions L x D x H (in.)	Voltage	Amps	NEMA	Ship Wt. (lbs.)	Cu. Ft.
CLBM-23R	1	3	27 x 33.5 x 78*	115/60/1	3.8	5 - 15P	350	20.5

\*Note: 78 in. height without casters

As continued product improvement is a policy of Traulsen, specifications are subject to change without notice.

Approved by \_\_\_\_\_ Date \_\_\_\_\_ Approved by \_\_\_\_\_ Date \_\_\_\_\_

**MODEL - CLBM-23R**

Full Height & Half Height Glass Door Models

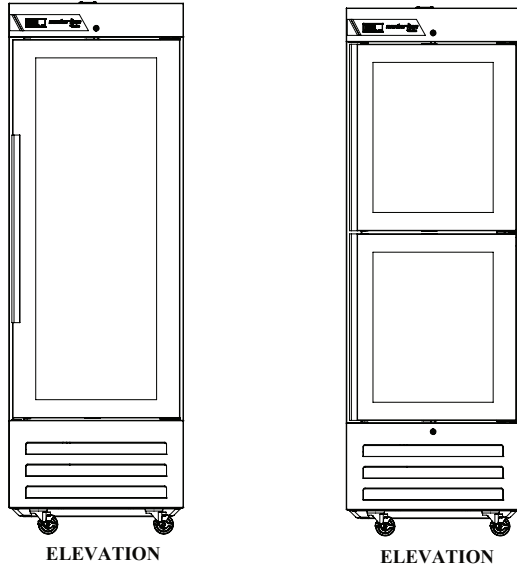

ELEVATION

ELEVATION

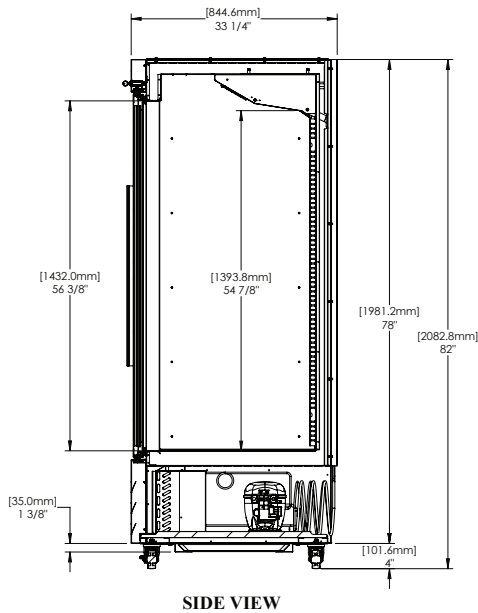

SIDE VIEW

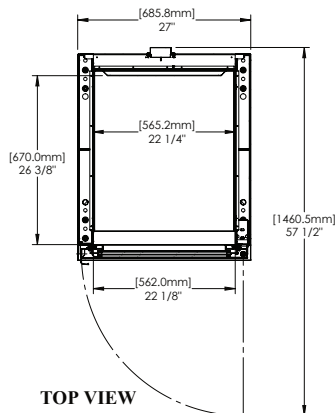

TOP VIEW

**SPECIFICATIONS**

**CONSTRUCTION, HARDWARE, INSULATION**

Cabinet sides, louver assembly and door frame(s) are constructed of stainless steel. Cabinet front, interior, and door liner(s) are constructed of anodized aluminum. The exterior cabinet top, back and bottom are constructed of galvanized steel. A set of four (4) 4" high casters are included. Doors are equipped with a gasket protecting retainer and removable plug cylinder locks. The cabinet is insulated with an average of 2-3/8" thick high density, non-CFC, foamed in place polyurethane insulation.

**REFRIGERATION SYSTEM**

A bottom mounted, self-contained, balanced refrigeration system using environmentally friendly, non-flammable R-450A refrigerant is conveniently located behind the one piece louver assembly. It features an easy to clean front facing condenser, capillary tube metering device, and an air-cooled hermetic compressor. A 9' cord and plug is provided. Standard operating temperature is 36°F to 41°F.

**CONTROLLER**

The easy to use electronic digital control is supplied standard. It includes a 3-Digit LED display, and a Fahrenheit or Celsius temperature scale display capability.

**INTERIOR**

Standard interior arrangements include three (3) epoxy coated wire shelves per section, mounted on pins. Shelves are full-width, and do not have any large gaps between them requiring the use of "bridge" or "junior shelves." Recommended load limit per shelf should not exceed 150 lbs.

**WARRANTY**

Both a 6 Year Parts & Labor Warranty and additional 1 Year on Compressor Parts Warranty are supplied standard.

MODELS	CLBM-23R
<b>ELECTRICAL DATA</b>	
Voltage	115/60/1
Full Load Amperes	3.8
<b>REFRIGERATION DATA</b>	
Refrigerant	R-450A
Refrigerant Charge oz.	14 (397 gr)
BTU/HR'   H.P.	1955   1/4
<b>SHIPPING DATA</b>	
Depth Crated in.	40 (101.6 cm)
Height Crated in.	85 (215.9 cm)
Length Crated in.	37 (94 cm)
Volume Crated cu. ft.	73 (2067.1 l)
Net Weight lbs.	305 (138.4 kg)
Gross Weight lbs.	350 (158.8 kg)

NOTES:

1. BTU/HR based on a 90°F ambient and 20°F evaporator

Equipped with one NEMA 5-15P Plug



**CAD and/or Revit Files Available**