

SHARE CART

52861

Reduce hunger and waste with a New Age Share Cart.

Elevate any school share program with a New Age Share Cart! This cart comes in many colors, and features two locations for custom signage to encourage students to share their individually packaged foods, milk, juice, fruit, and more.

The cart comes with cold food pans that, when frozen, can hold food safely for 6-8 hours **eliminating the need for ice!** Heavy duty casters, a lightweight design, and a convenient push handle make this cart easy to maneuver.



Comes with HACCP compliant cold food pans.



Optional Cold Pan Shelf (#52918BLUE)



Optional Solid Shelf (#52919ORANGE)

Two locations for custom signage.

Top shelf designed to hold two Coldmaster CoolCheck™ drop-ins. (pans included)

Push handle.

Slanted second shelf for easy access and storage.

Reinforced base shelf for misc storage.



52861GREEN

NO ICE NEEDED

40% of food is thrown out in America, yet **14 million** children go to bed and to school hungry.

Students can leave unwanted, unopened food and drinks in the Share Cart, where other students can help themselves.

NEW AGE INDUSTRIAL

NewAgeIndustrial.com | 800-2550-0104

SHARE CART

52861

Model No.	Size D - H - L	Ship Lbs.
52861*	23 1/4" x 70" x 29 7/16"	100

* Must select color option.

Four 5" plate type casters, two swivel, two swivel with brake.
All welded aluminum construction.

Note: Poly food boxes, custom signs and any other accessories are not included and must be purchased by end user.

Factory Options: - Must select color option.

- **52918 - Cold Pan Shelf -**

Hinged, drop-down shelf built to hold 1/2-size cold pan.

- **52919 - Computer/Tablet Shelf -**

Hinged, drop down shelf for a computer/tablet.

- **Color options:**

- Red** - Add "RED" suffix to model #.
- Orange** - Add "ORANGE" suffix to model #.
- Yellow** - Add "YELLOW" suffix to model #.
- Green** - Add "GREEN" suffix to model #.
- Blue** - Add "BLUE" suffix to model #.
- Purple** - Add "PURPLE" suffix to model #.
- Black** - Add "BLACK" suffix to model #.

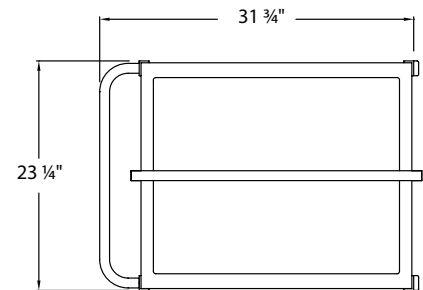

Note: Poly food boxes, custom signage and any other accessories are not included and must be purchased by end user.

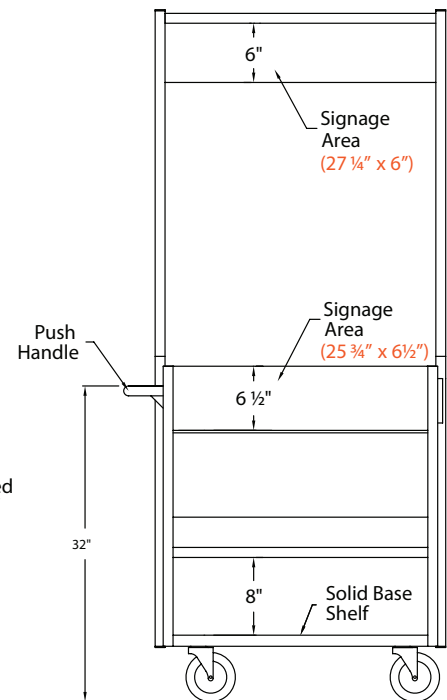
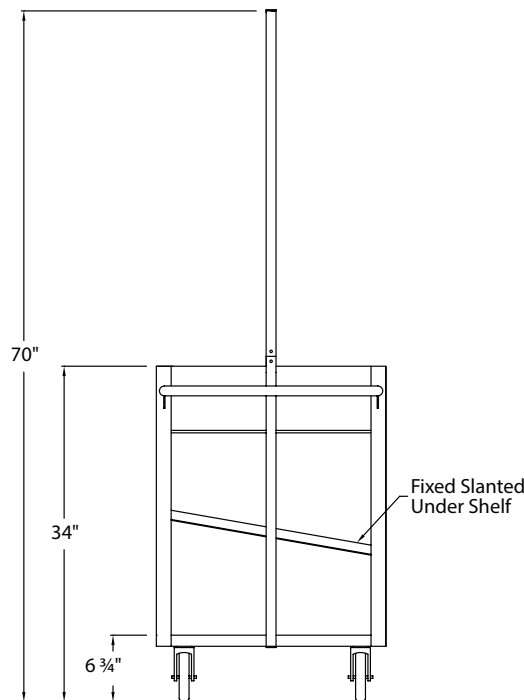

This information is for general sales and engineering use only. New Age Industrial reserves the right to modify or make changes at any time without notice to materials and specifications.

01-30-2024

