

Electric Heavy Duty Utility Cart

Power Assist Stainless Steel

Model 173670

Ideal For Hauling Heavy Loads Over Long Distances And Up And Down Inclines

Benefits

- Transport more supplies and equipment with less staff
- Easily maneuver up to 700 lbs with a single operator
- Labor savings and efficiency – one person and one cart can move more
- Worker safety – reduces operator fatigue and strain

Features

- Battery-powered integrated hub motor wheels provide safe, easy power assist
- Dual hot-swappable rechargeable batteries provide two hours of continuous use
- End-mounted motion control panel with battery level meter
- Forward and reverse controls allow operator to push or pull cart
- Emergency stop feature to ensure operator safety and prevent injuries
- All-welded stainless steel heavy-duty construction is easy to clean and sanitize

Casters

- Two all-swivel 6" wide-tread non-marking with brake, and two 6" hub motor powered rigid wheels



Model 173670



Speed/Direction Thumb Control



Hot Swappable Batteries



Emergency Stop Button



Integrated Hub Motor Wheels



24V Lithium-Ion Batteries



Battery Level Meter

Spec. # _____

AIA # _____

Lakeside Manufacturing, Inc.

4900 West Electric Avenue • West Milwaukee, WI 53219 U.S.A.

800-558-8565 • 414-902-6400 • Fax 414-902-6446 • info@elakeside.com • www.elakeside.com/foodservice

Electric Heavy Duty Utility Cart

Model
173670

Power Assist Stainless Steel

Specifications:

Lakeside model 173670 is of welded stainless steel U-frame construction. Shelves are 18-gauge and U-frame is 1" x 1" x 1/8" angle stainless steel. The battery-operated power system features 2 ea. power assist wheels. Wheel motion is controlled by an end-mounted thumb action control panel with emergency stop button and battery level meter. Motion system is powered by dual hot-swappable and rechargeable 24V lithium-ion batteries providing two hours of continuous use. Casters are two each non-marking 6" wide tread swivel casters with brake, and 2 each front end mounted power hub casters.

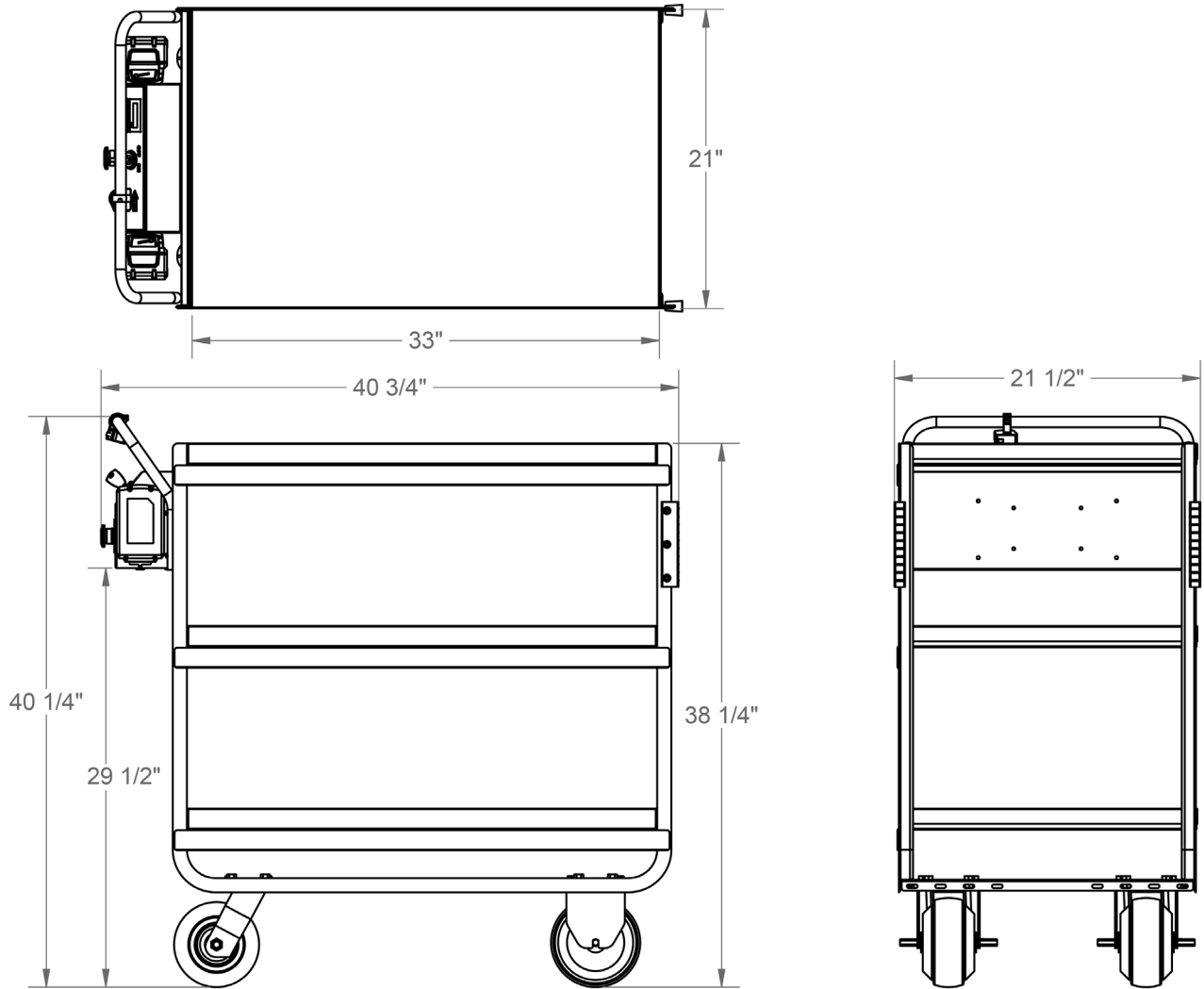

Model Information

Model	Shelf Description			Overall Size			Unit Weight	Case Weight
	# of	Size	Clearance	L	W	H		
173670	3	21" x 33" (533 x 838)	11-3/8" (289)	40-3/4" (1035)	21-1/2" (546)	40-1/4" (1022)	100 (45.4 kg)	130 (58 kg)

Measurements in () denote metric millimeters, unless otherwise specified.



Lakeside Manufacturing, Inc.
4900 West Electric Avenue • West Milwaukee, WI 53219 U.S.A.
800-558-8565 • 414-902-6400 • Fax 414-902-6446
info@eLakeside.com • www.elakeside.com/foodservice