

PROJECT NAME: \_\_\_\_\_ LOCATION: \_\_\_\_\_

ITEM: \_\_\_\_\_ MODEL: \_\_\_\_\_

## FEATURES LIST



- Utilizing conveyor speed, not temperature, to determine toasting color, allows for instant adjustment of toasting time
- 4-position toast selector switch:
  - Off
  - Toast
  - Buns
  - Stand-by Mode
- Allows for toasting of bread products up to 3" (76 mm) thick and 9 5/8" (245 mm) wide
- Easy-to-load rack with front or rear discharging
- Permanently lubricated 50/60 Hz motor
- V-shaped reflectors help capture and redirect heat
- Long lasting serpentine metal sheathed heating elements
- Discharge and crumb trays are removeable for easy cleaning
- Toasts up to 300 bread products per hour (Toasting capacity may vary by moisture, sugar content and thickness)
- All models ship with 4" (102 mm) adjustable legs, a feed ramp, a removable crumb tray, a front discharge chute and rear discharge tray
- One year parts and labor warranty on metal sheathed elements



Specifications subject to change without notice

Approvals:

## PLAN VIEW

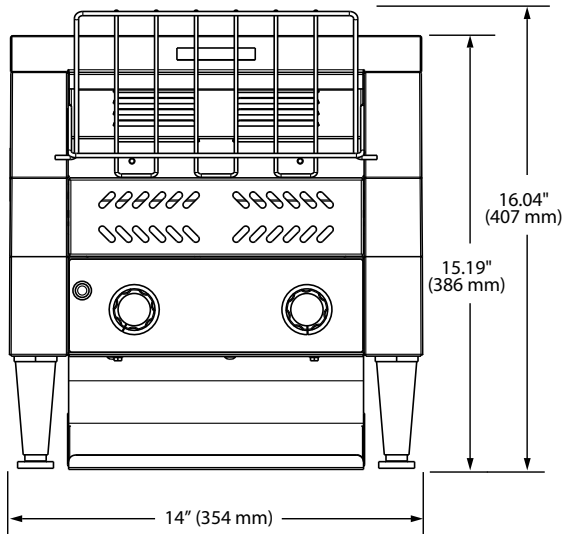

FRONT VIEW

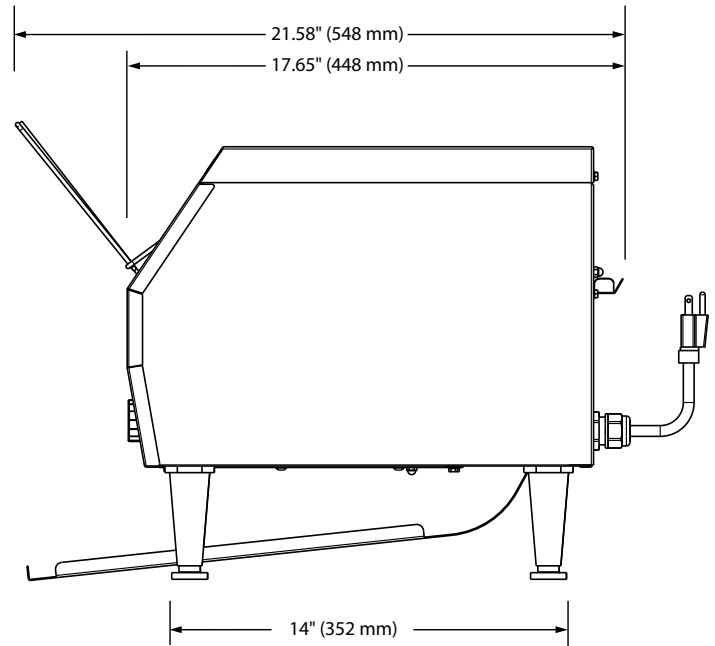

SIDE VIEW

### SPECIFICATIONS Conveyor Toasters

Model	Dimensions (W x D x H)	Volts	Hertz	Watts	Amps	Plug	Ship Weight*
CENCTH-120	14.43" x 21.58" x 16.04" (367 x 548 x 407 mm)	120	50/60	1790	14.9	NEMA 5-15P	44 lbs. (20kg)

\* Shipping weight includes packaging.

### CORD LOCATION

Back of unit, lower right corner.

### PLUG CONFIGURATION

NEMA 5-15P

