



Mega Top Salad/Sandwich Prep Tables



Grista's Mega Top Salad/Sandwich Prep Tables are constructed of heavy duty stainless steel making them strong and durable enough to survive in any kitchen environment. Store all of your condiments, meats and vegetables in the cold topping area that can hold a variety of different sized food pans up to 6" deep. The oversized hinged insulated cover keeps the food items cold when not in service. Store additional items below in the cabinet for quick access when needed. All salad/sandwich prep tables come with 4" casters, plastic coated wire shelving and a 3/4" thick polyethylene cutting board. These models are ETL Listed and ETL Sanitation. They are backed with a 1 year warranty on parts and labor and a 5 year warranty on the compressor.

Product Features

- 430 series stainless steel exterior
- Painted aluminum interior
- Environmentally-friendly R290 refrigerant
- Precise digital temperature controller with LED display
- Foamed-in-place polyurethane high density cell insulation throughout the entire cabinet
- Oversized hinged insulated lid
- Removable door gasket
- Recessed door handles
- 3/4" thick removable polyethylene cutting board
- Clear plastic food pans included
- (4) 4" casters (2 locking and 2 non-locking)



GRSLM-2D



Specifications

Model Number	GRSLM-2D
Doors	2
Shelves	2
Net Volume (Cu. Ft.)	12 Cu. Ft
Overall Dimensions (in)	47"W × 34D" × 46"H
Interior Dimensions (in)	43"W × 24"D × 24"H
Horsepower	1/4+
Refrigerant	R290
Voltage/Hertz/Phase	115/60/1
Amps	6.1
Net Weight (lbs)	282 lbs
Gross Weight (lbs)	407 lbs
Shipping Dimensions (in)	51"L × 34"W × 49"H

CALL FOR MORE INFO: 1.800.223.7750

VISIT: www.admiralcraft.com



Mega Top Salad/Sandwich Prep Tables

Plan Views

GRSLM-2D

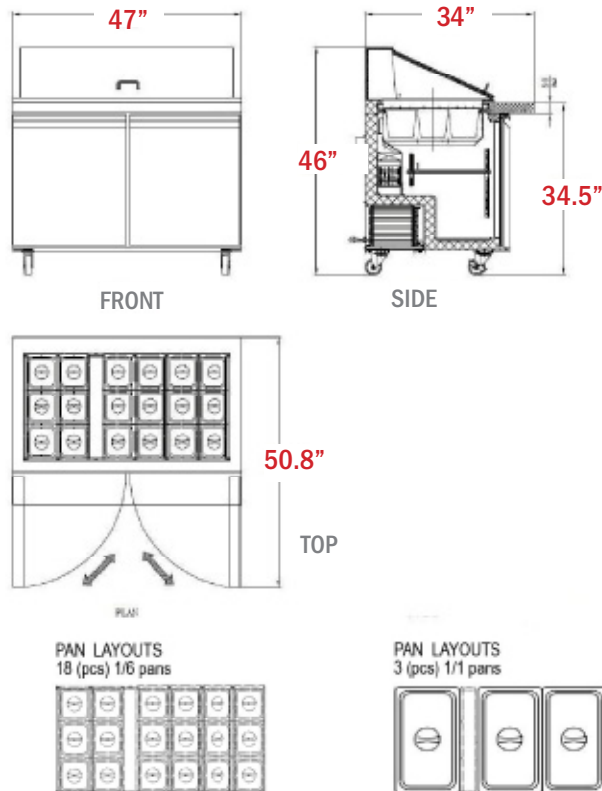

Features

Refrigeration System

- Refrigeration units use environmentally friendly R290 refrigerant
- Maintain a temperature range of 33°F–40°F
- Rugged built axial evaporator fans run efficiently with low velocity and high volume air flow

Electrical Control

- Electric LED temperature controller provides a digital display of cabinet temperatures and allows for easy temperature adjustments when necessary
- Temperature controller initiates automatic defrost schedule for worry free use
- 7 foot power cord with NEMA 5-15 plug

Cabinet Construction

- Exterior is constructed of 430 stainless steel including the doors
- The cabinet is insulated throughout with a foamed-in-place high density cell polyurethane insulation

Door(s)

- Stainless steel exterior with matching aluminum liner on the inside
- Positive self-closing doors with micro-switch that shuts the evaporator fans off when the door is open
- Recessed handles are built into the door for easy opening and closing
- Removable door gasket for easy cleaning

Shelving

- Adjustable plastic coated steel shelves that have a load capacity of up to 90 lbs per shelf

Model Features

- 19" extra deep, 3/4" thick polyethylene cutting board that runs the full length of the unit
- Insulated hinged lid to keep food cold while not in use
- 4" casters come standard on all stainless steel models 2 locking and 2 non-locking.
- 3/4" thick poly cutting board
- Clear plastic food pans included

CALL FOR MORE INFO: 1.800.223.7750

VISIT: www.admiralcraft.com